



HAM NEWS

MARCH-APRIL, 1960



THE TC-75

A MOBILE TRANSMITTER/ CONVERTER FOR 3.9 MC.

By F. J. Pinkerton, W4QVL*

When the average radio amateur considers building a mobile rig, he is faced with several questions that must be answered, such as:

1. How much power?
2. How many bands?
3. VFO or crystal controlled?
4. Space requirements?
5. Type of converter for receiving?
6. Will it please the XYL?

In my case the first three questions were easy. I knew exactly what I wanted, a low power, 3.9-megacycle crystal-controlled transmitter. Question 4 was a stickler; I had a 1959 "No-roomobile," and by solving the space problem, I answered questions 5 and 6.

The TC-75 is a 3.8 to 4.0-megacycle, 15-watt crystal-controlled transmitter and a crystal-controlled converter in a single package only 7 x 3 x 5 inches in size. The unit was painted to match the color scheme of the car's interior; this, plus the small size, cer-

(continued on page 3)



HANGER FOR MICROPHONE

Also in this issue—

| | |
|--|------------|
| Scanning the Spectrum..... | see page 2 |
| General Electric Enters Citizens Radio Field..... | page 6 |
| THE HANDY ANDY TOWER..... | page 8 |
| 1959 Edison Award Recipient..... | page 12 |

—*Lighthouse Larry*

Copyright, 1960, by General Electric Company

*W4QVL is a design engineer in Standard Mobile Design Engineering at General Electric's Communication Products Department, Lynchburg, Virginia. This department produces the famous "Progress Line" of two-way mobile radio equipment.

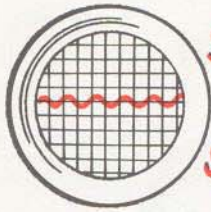

SCANNING the SPECTRUM

COMING NEXT ISSUE . . .

. . . information on new rectifier tube types, and details on a pi-network type antenna tuner, and a simple accessory which permits monitoring of transmitter signals on almost any test oscilloscope. This issue will be available from your G-E Tube distributor about May 1 — and if he doesn't have copies, ask him to order a quantity for your local radio amateurs.

73 TO FORM 73B . . .

Our well-known Log Form blank QSL card (labeled Receiving Tube Department Form 73B) will be discontinued when the present stock of cards runs out. We have about a four-month supply left, but when these are gone, there will be no more.

The minimum quantity is 250 cards, which sell for \$1.00 postpaid. Order larger quantities in multiples of 250 cards (and dollars, too). Make checks and money orders payable to "General Electric Company," and address your letter to me in Owensboro, Ky.

CIRCUIT CHANGE . . .

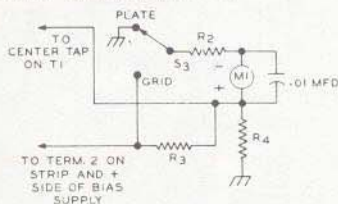

The plate current metering circuit for the GL-813 KILOWATT GROUNDED-GRID LINEAR AMPLIFIER (See G-E HAM NEWS, November-December, 1959, Fig. 1, page 4) should be connected as shown above. Complete details are available in a bulletin, which also has additional construction and component information.

WANTED: HAM COLUMNISTS . . .

Does your club want continuous publicity about the activities of radio amateurs in your community? Try establishing a regular column on amateur radio in your local newspapers.

NOTE: The disclosure of any information or arrangements herein conveys no license under any patents of General Electric Company or others. In the absence of an express written agreement to the contrary, the General Electric Company assumes no liability for patent infringement (or any other liability) arising from the use of such information by others.

A pioneer such column is "HAM ANTENNA," which appears in every Sunday edition (circulation: over 500,000) of the *Cleveland Plain Dealer*. It is compiled by Harry A. Tummonds, W8BAH, and includes happenings in the fifteen amateur radio clubs in the Cleveland area, get-acquainted information on amateur radio for the public, and newsy items about the local hams.

Harry, incidentally, is a G-E Tube distributor, and makes several hundred copies of *G-E HAM NEWS* available to radio amateurs in his area.

If your club now publishes a club paper, many of the items therein could be rewritten into a newspaper column. Try it and let the public know about the good work we hams are doing in their interest.

EDISON AWARD SPECIAL CITATIONS

In addition to the principal 1959 Edison Radio Amateur Award to W8AEU (see page 12), Special Citations were awarded to the following radio amateurs, recognizing their outstanding public service in 1959:

W3BHK — J. William Bennett, Washington, D.C.;

W6MEZ — Raymond E. Meyers, San Gabriel, Calif.;

W7BA — Loyd Peek, Seattle, Washington.;

W0KQD — Mrs. Irene H. Craft, Alamosa, Colorado.;

CHICAGO AMATEUR RADIO DISASTER CORPS — a group headed by W9NOE, Richard D. Cortwright; and Leslie E. Tanner, W9ING, of Chicago, Ill.

Congratulations to these amateurs, and my thanks to all persons who participated in the Eighth Annual Edison Award program.

435 MILLION TUBES . . .

. . . yes, that's the number of receiving tubes expected to be placed in service by the electronics industry in the United States during 1960, according to a recent forecast by L. B. Davis, General Manager of G.E.'s Electronic Components Division.

We've been "guesstimating" how many of these tubes will go into new amateur radio equipment — and as replacements in existing gear — and our figure is over a million.

The forecast also reports power tube sales up to 10 percent, transistor usage up to 130 million units, and nearly 13 million television picture tubes to be placed in service. Receiving tubes, however, will remain as the mainstay of the electronic components industry, at the same level as in 1959.

Tunnel diodes, which were first introduced by General Electric in 1959, will continue to be widely discussed and experimented with during 1960, but samples will be limited to small quantities pending development of circuits.

G-E tunnel diodes are made by our Semiconductor Products Department in Syracuse, N.Y.

—Lighthouse Larry

THE TC-75

(continued from page 1)

tainly filled the bill for question number 6.

The circuit of both the transmitter and converter, shown in Fig. 1, is straightforward and no complications should result if care is taken in the layout and wiring. One half of a 12AT7 is the crystal-controlled oscillator with a slug-tuned coil and fixed capacitor in the plate circuit. This drives a 6360 twin pentode with both sections in parallel. (Ed. note: A 5763 single pentode can be used in this transmitter in place of the 6360 twin pentode at the 15-watt input rating.) The tank coil is slug-tuned, with a fixed mica capacitor across

it eliminating the bulky tuning capacitor usually required. A variable padding capacitor, C_1 , in series with the output link coupling coil, L_3 , is used to adjust the loading on the final stage. Two sets of contacts on the 4-pole, double-throw transmit-receive relay (K_{1A} and K_{1B}), switch the antenna from the transmitter to converter, and short out the input coil of the converter when the relay is in the transmit position.

Plate modulation of the 6360 final amplifier is accomplished with a 12AX7 twin triode.¹ The other half of the 12AT7 is an audio voltage amplifier, driven by a carbon microphone (continued on page 5)

TABLE I — PARTS LIST, TC-75

| | |
|-----------------------|--|
| C_1 | 65-340 mmf ceramic padder. (El Menco 303) |
| C_2 | 275-970 mmf ceramic padder. (El Menco 306) |
| F_1 | 50 turns, $\frac{1}{2}$ inch in diameter wound in two layers, No. 16 enameled wire, self-supporting. |
| I_1 | 6 volt, 250 ma pilot bulb (#44) and bracket. |
| I_2 | 12 volt pilot bulb (#53) and bracket. |
| J_1 | 4 pin jack for microphone. |
| J_2, J_3 | Midget Phone type jack. |
| K_1 | 4 pole, 2 position miniature relay, 6-volt DC coil (Potter & Brumfield MH17D-6V). |
| L_1, L_4, L_7 | 36-64 microhenry coil, slug tuned (North Hills PF-120F). |
| L_2 | Coil, slug tuned, 30 turns, No. 20 enameled wire, close wound. (Form is CTC PLS7). |
| L_3 | 7 turns wound over grounded end of L_2 , No. 20 enameled wire. |
| L_5, L_6 | 7 turns wound over grounded ends of L_4 and L_7 , No. 30 enameled wire. |
| M_1 | 0-200 microamp, 1-inch diameter milliammeter. (International 100). |
| P_1 | 8 pin male octal plug and chassis plate (Amphenol 86CP8 with 12-001-03 plate). |
| R_1 | 32 ohms, 1 watt (1-68 and 1-56 ohm, $\frac{1}{2}$ -watt resistor in parallel). |
| R_2 | 2 ohms, 1 watt (2-5.6-ohm and 1-6.8 ohm $\frac{1}{2}$ watt resistors in parallel). |
| S_1 | 3 pole, 2 position miniature rotary switch. |
| S_2 | Double pole, 2 position toggle switch. |
| T_1, T_2 | Surplus 3-winding transformers; see footnote 2 on page 5 (Triad A-81X also suitable for T_1 ; Triad A-1X suitable for T_2). |
| T_3 | Modulation transformer; primary, 10,000 ohms, center-tapped; secondary, 5,000 ohms, 10 watt-rating (Triad M-1X, or equivalent). |
| X_1 | 3800-4000 kc crystal (FT 243 case) for desired transmitter frequency. |
| X_2 | 2500-3250 kc crystal, or 4550-5300 kc crystal (FT 243 case) for converter. |

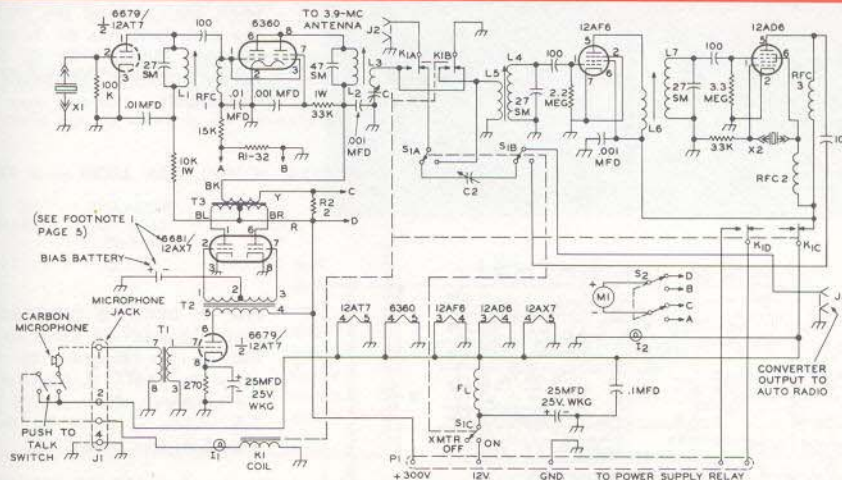
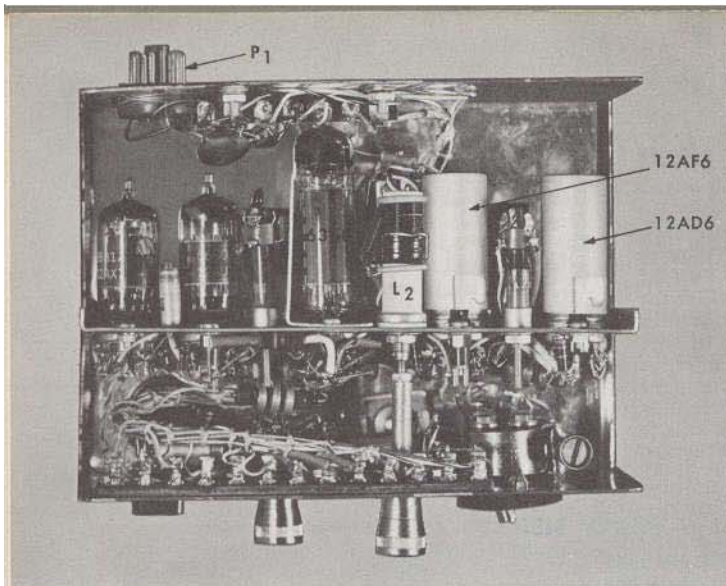
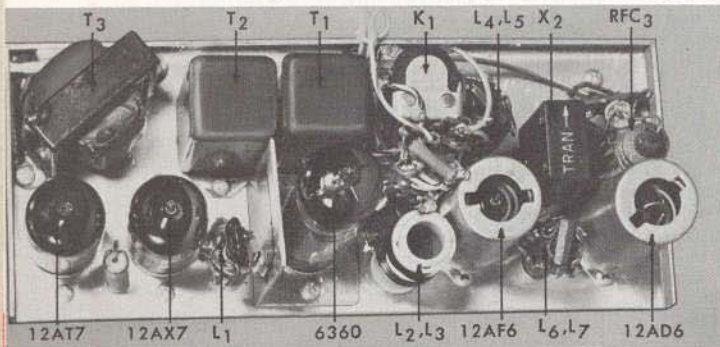

FIG. 1. SCHEMATIC DIAGRAM of the TC-75 transmitter/converter. The transmitter and modulator are at the left; and the crystal-controlled converter is at the right. Capacitors are in mmf, unless otherwise noted; silvered mica are marked "SM." Resistances are in ohms (K = 1000), $\frac{1}{2}$ watt rating if not marked 1 watt, or 2 watts.



TOP VIEW OF THE TC-75, showing the location of major components in the cabinet. The parts placement allows sufficient room for tubes to be removed from their sockets.



REAR VIEW of the center chassis. Note the r.f. shield between the 6360 tube and the 12AT7 oscillator tube. The cabled leads at the top of the picture run to the parts and controls on the front panel. Power connections to P₁ on the cabinet are included in this cable. The antenna lead runs directly from relay contacts K_{1A} to J₂ on the rear panel.

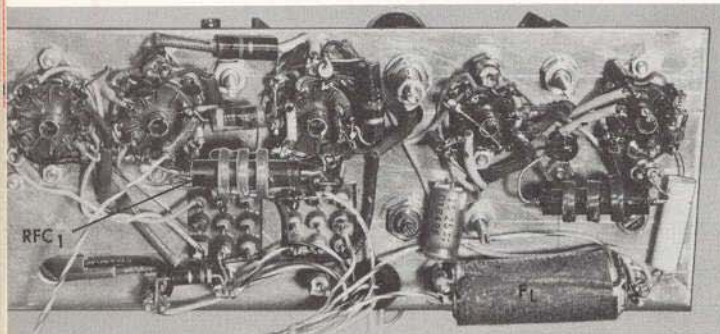

FRONT VIEW of the center chassis, showing the wiring and placement of small parts around the tube sockets. The nine terminals on T₁ and T₂ can be seen through the 3/4 x 3/4-inch square cutouts in the chassis for these components.

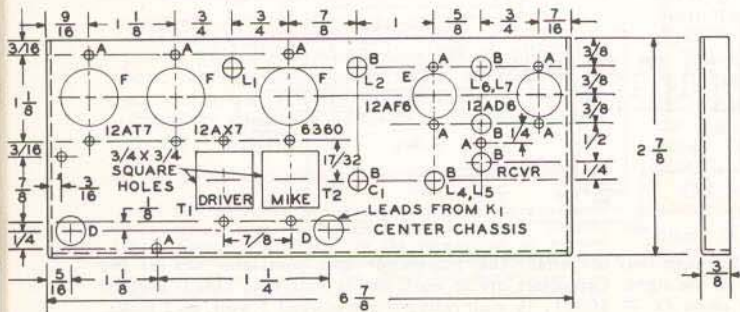

FIG. 2. DRILLING DIAGRAM for the center chassis. All holes sizes identified on the diagram by letter are given in TABLE II. Over-all size of the aluminum sheet should be 7 3/4 x 3 5/8 inches, to allow for the 3/8-inch wide lips, plus bends.

THE TC-75

(continued from page 3)

through a matching transformer (T_1). Microphone voltage is obtained from the 12-volt DC supply.

The converter has two of the "hybrid" tubes that require only 12 volts on the plates and screens. A 12AF6 pentode is the RF amplifier, and a 12AD6 pentode is the mixer and crystal-controlled oscillator stage. The crystal is in a Pierce type circuit with the 12AD6 screen grid as the plate of the oscillator. A padder capacitor, C_2 , in series with the antenna coil, L_5 , permits the 3.9-megacycle whip to be used as a broadcast receiver antenna.

TRANSFORMERS T_1 and T_2 are of a surplus variety and advertised by several firms² as good for phasing type single sideband exciters; phone patches, microphone transformers, interstage transformers and other uses. They have three windings, each center tapped, one having high impedance, one medium impedance and one low impedance winding.

The relay, K_1 has a 6-volt coil, connected in series with a No. 44, 6-volt pilot lamp, I_1 . If a 12-volt relay is available, a pilot lamp rated at 12 volts (No. 53), should be wired in parallel with the relay coil.

THE CABINET for this model is home-fabricated, but any of the commercially available 1 x 5 x 3-inch aluminum boxes (LMB No. 145 interlock type; or No. SL-145 snaplock type) can be used to house the TC-75 instead. This

The 12AX7 twin triode (G-E 6681 Communication tube type; or, 5751 G-E Five-Star tube type) is designed primarily for class A audio voltage amplifier service. However, in experimental amateur service, the short operating periods and intermittent waveform of voice audio signals usually will not overload a 12AX7 when operated as a class B audio power amplifier delivering up to 7 watts output. The 12AX7 is not recommended for commercial service in this application.

To obtain more power output from the class B stage in the TC-75, connect two 12AX7 tubes in push-pull parallel. Substitute types 12AT7, 12AU7, or 12BH7, all having higher plate dissipation ratings, and higher power output capability (be sure to apply the correct grid bias voltage for these types).

The 12AX7, because of its high μ , may be operated as a zero-bias class B amplifier up to 200 plate volts. From 220 to 300 plate volts, apply -1.5 volts grid bias. Over 300 plate volts, apply -3 volts grid bias in the driver transformer (T_2) center tap, as shown in the schematic diagram, p. 1.

TABLE II — DRILL AND PUNCH SIZES

| LETTER ON DIAGRAM | DIAMETER OF HOLE (inches) | TOOL |
|-------------------|---------------------------|--------------|
| A | 0.116 | No. 33 drill |
| B | $\frac{1}{4}$ | drill |
| C | $\frac{5}{16}$ | drill |
| D | $\frac{3}{8}$ | drill |
| E | $\frac{5}{8}$ | punch |
| F | $\frac{3}{4}$ | punch |
| G | 1 | punch |
| H | $1\frac{1}{8}$ | punch |

FIG. 4. DRILLING DIAGRAM for the front and rear sides of the cabinet bottom. Hole sizes are given in TABLE II, and are for the components actually used in constructing this model.

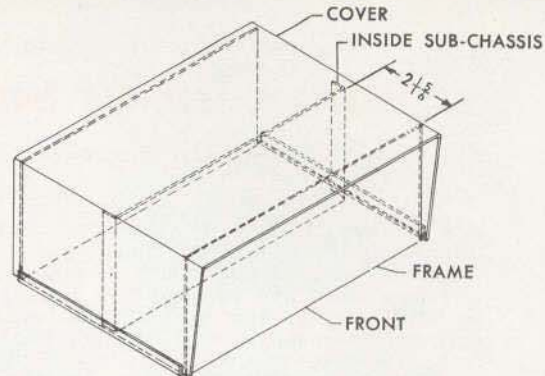

FIG. 3. ASSEMBLY DRAWING of the cabinet top and bottom, showing the position of the center chassis in the cabinet. The cabinet and chassis are fastened together with self-tapping screws.

type of box is excellent for this application; the part with the small flanges forms the cabinet, with one 7" x 3" side as the front, and the other as the rear. The other part of the box forms the cover and is mounted under the dash by appropriate holes drilled to match existing bolts in the car.

Drill and mount all the components on the front and rear panels. A terminal strip is placed on the inside top edge of each panel to terminate the wires from the parts. The front panel should have 13 terminals, and the rear panel, 5 terminals. Cabled wires connect each of these terminal strips to proper place on the center panel.

(continued on page 11)

²Transformers T_1 and T_2 can be obtained from Burnstein-Applebee, Kansas City, Mo. (Cat. No. 18C647); or, from Barry Electronics, 512 Broadway, New York 12, N. Y.

T_1 becomes a microphone transformer by using the low-impedance winding (terminals 7 and 9) for the microphone, and the high-impedance winding (terminals 1 and 3) for the 12AT7 grid. For the driver transformer, T_2 , the medium-impedance winding (terminals 4 and 6) is used for the 12AT7 plate, and the high-impedance winding (terminals 1 and 3) and its center tap (terminal 2) drives the 12AX7 grids.

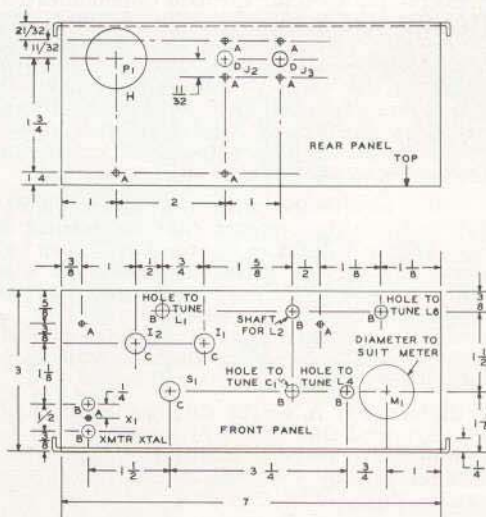

GENERAL ELECTRIC ENTERS CITIZENS RADIO FIELD

— Introductory Class D Prices for Hams

A pioneer of three decades as a manufacturer of its own mobile radio products, General Electric Company has broadened its communications line by adding E. F. Johnson's *Viking Messenger* to G-E products sold nationally through several hundred manufacturer's representatives.

Announcing the action, Kent J. Worthen, W4EYE, national sales manager for General Electric two-way radio equipment, explained that G-E's own current factory programs at Lynchburg, Va., are aimed at providing communication devices to meet the expanding needs of governmental agencies, military services, municipalities and businesses requiring maximum equipment performance in the commercial VHF and UHF communication bands.

"In providing a complete communications line," Worthen points out, "we feel the need to include 27-megacycle equipment to serve the growing Citizens Radio market. The Class D Citizens Band rules, of course, provide for amplitude-modulated equipment, which General Electric has not produced for several years. For this reason, we elected to distribute Johnson's *Viking Messenger* rather than divert production to AM devices at this time."

General Electric two-way radio sales offices in all parts of the United States, including Alaska and Hawaii, will sell the *Messenger* equipment and the units will be installed and serviced by General Electric's extensive network of authorized independent service stations.

H. N. McNeill, national product service manager for General Electric Communication Products Department, Lynchburg, said the *Messenger* was subjected to intensive field tests by General Electric. The Johnson firm is one of the country's recognized leaders in the manufacture of ham radio transmitters and began a Citizens Band development program in 1958 which culminated in the introduction of the present *Messenger*.

"Our experience with the *Messenger* to date," McNeill says, "is that its quality is outstanding. Because there have been no particular service problems associated with the equipment, in most instances our independent service stations will be able to provide maintenance at a routine minimal charge, so the owner of the unit will know immediately what the costs will be."

Under FCC rules, 23 Citizens Band channels are available in the 27 megacycle range. Equipment may be obtained for personal or business use by any U.S. citizen 18 years of age or older, subject to FCC licensing.

Regulations for Citizens Band differ from Ham bands in that the person transmitting

must be attempting to call a specific person and not trying to stimulate conversation with anyone who happens to be on the air. Each message must meet a specific communications need. However, personal talk between auto and home, between home and boat, or similar points is allowable. It is in this area of communications that much of the equipment manufactured to date has been used.

The *Messenger* is compact, lightweight and exceptionally easy to install anywhere. The complete transceiver measures just 5½ inches high, 7 inches wide, 11¾ inches deep.

Space is included in the unit for five of the 23 available Citizens Band channels. By simply moving the selector switch on the front panel to the desired position, any one of the five may be selected for operation.

The equipment as designed is not operative in ham bands. However, the E. F. Johnson Company says the *Messenger* can be adapted to a 10-watt 28-megacycle transceiver with some changing. It involves some coil retuning, changing two resistors and adding one wire. (Further information on this subject can be obtained by writing directly to Customer Service Dept., E. F. Johnson Company, Waseca, Minn.)

Normally, crystals for one Citizens Band channel are supplied with the standard *Messenger* package at \$139.75, which includes the unit, furnished with microphone and cord and necessary power cords.

However, as a special introductory offer for readers of *G-E HAM NEWS*, the General Electric Communication Products Department will make available the standard package (Model J242-128, 12 volts DC/115 volts AC; or Model J242-127, 6 volts DC/115 volts AC), at \$139.75 with four extra crystals and a high efficiency short collapsible chrome-plated antenna that mounts on the back of the *Messenger*. These four crystals and antenna will be included at no extra cost on cash orders sent directly by hams to the General Electric Communication Products Department, Box 4197 Lynchburg, Va., with postmarks no later than May 31, 1960.

Checks should be made payable to General Electric Company. Model J242-128 (12 volt/115) or Model J242-127 (6 volt/115) should be specified. Full remittance should be included with orders (No C.O.D.'s, please).

The *Messenger* comes equipped with Crystal J250-918 (Channel 18), as standard. On orders received in Lynchburg before May 31, antenna J137-804 will be included plus crystals for Channels 1, 5, 7 and 22.

— *Lighthouse Larry*

At Lynchburg, Va., national headquarters for the General Electric Communication Products Department, Product Service Engineer Harry Clare checks battery drain of high-performance Transistorized Progress Line, manufactured by G-E and now being shipped in quantity. Receiver and power supply are fully transistorized. Four tubes are used in transmitter. On standby, ready to receive a call with full volume, the unit drains only 0.040 amps from the battery — the lowest drain achieved in communications industry to date. The same sales and service outlets which handle the Progress Line nationally will also handle Messenger Citizens Band equipment.



Approximately 900 authorized independent General Electric mobile communications service stations in all parts of the nation are participating in General Electric's new Citizens' Band service program. The years of experience gained by this group in servicing G-E's tubularized Progress Line, used in low-band, high-band and 450-megacycle frequencies, will be carried over to the Viking Messenger, being distributed by G-E for the 27-megacycle Citizens Band.



For hams who act fast, there's a special introductory offer on this Viking Messenger Class D Citizens Band unit. On orders received by G-E Communication Products Department, Lynchburg, Va., prior to May 31, 1960, G-E will include crystals for four extra channels plus a collapsible antenna at the standard price of \$139.75, which normally includes a crystal for only one channel, plus mike and necessary power cords. (See story at left.)



THE HANDY ANDY TOWER

By A. C. (Andy) Sturgis, W4DVL*

NEED A LOW-COST, easy-to-build, serviceable antenna support? Read how W4DVL has designed a simple 32-foot high tripod mast which will solve many amateurs' skywire problems.

VERSATILITY IS THE NICKNAME for the HANDY ANDY TOWER, since it can be used to support the ends or center of dipole and long-wire antennas, keep a vertical antenna aimed skyward, or support a beam and rotator weighing up to about 35 pounds. Several masts, identical to that in the picture on this page, have been put up at stations in W2-land. All have withstood severe weather conditions with no failures.

This tower can be assembled and installed by one person in almost any location over a week end, including time for the paint to dry.

The over-all assembly of the tower is shown in Fig. 1. Note the similarity to the famous "A-frame" mast, with a third base leg added. In addition, W4DVL has devised simple but effective underground base anchors which are essential if the tower will not be guyed. The over-all load of the tower is equally divided among the three legs. Materials and hardware required for construction are listed in TABLE I.

THE TOWER CAN BE CONSTRUCTED with simple hand tools: a $\frac{3}{8}$ -inch diameter wood bit and brace; claw hammer, screw driver, pliers, hand saw and tape measure. For best results, good straight lengths of wood for the legs and top section (parts 1, 2, 3 and 4), free of knots, cracks and other imperfections, should be selected. Of course, the braces and short pieces usually can be cut from between imperfections in the 1 x 2-inch x 16-foot pieces.

A fairly flat working space about 35 feet long and 10 feet wide is desirable for assembling the tower. Start with the assembly of the front support legs (parts 1 and 2) and the upper mast section (part 4). Lay two of the twenty-foot 2 x 2's, and the 16-foot 2 x 2 on the working surface so that they overlap as shown in Fig. 2.

Clamp the pieces together and drill one $\frac{3}{8}$ -inch diameter hole through all three pieces. Run a $\frac{3}{8}$ x 6-inch carriage bolt through the hole, put on a washer and tighten up the other carriage bolts, washers and nuts. Draw up tightly on all three nuts to firmly seat the washers in the wood. Next, assemble the third 20-foot long 2 x 2 (part 3) base leg, as shown in Fig. 3, and tighten all carriage bolt nuts firmly.

The bottom ends of the three base legs can now be spread apart with temporary strips of wood about $3\frac{1}{2}$ feet long, so that the points where the permanent spreaders (part 5) will be assembled are 4 feet apart. Notice that legs Nos. 1 and 2 may have a tendency

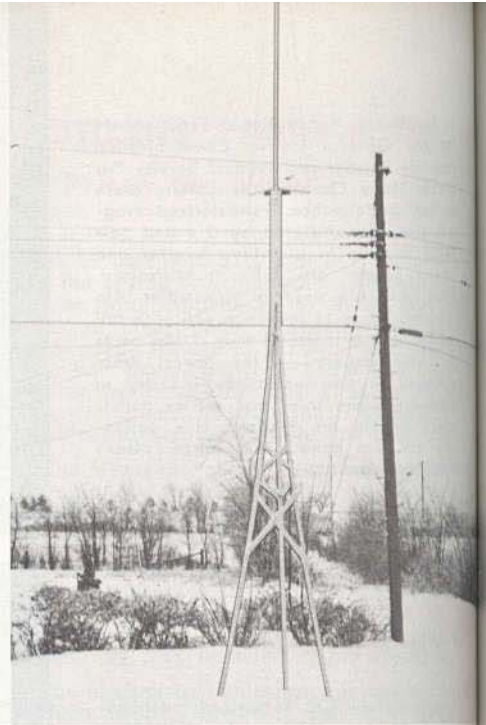

HANDY ANDY TOWER installed in snowy W2-land. If 22-foot long 2 x 4-inch lumber is substituted for the 2 x 2-inch lumber used on this model, over-all heights of 40 feet are possible.

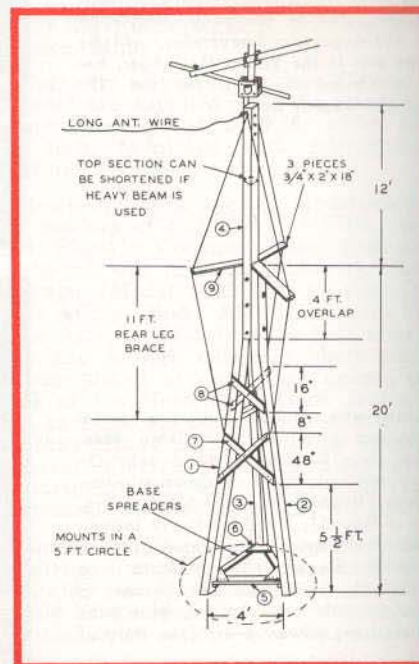

FIG. 1 ASSEMBLY DRAWING for the tower. Dimensions of all wood parts are given in TABLE I.

* W4DVL is an engineer with the Terminal Equipment Engineering group of General Electric's Communication Products Department, Lynchburg, Virginia.

to twist, due to the tri-directional tension on all three legs when spread out.

Cut the base spreaders to fit, trimming the ends of the two spreaders running to the No. 1 leg to the proper angle, as shown in the over-all view, Fig. 1. (Remember the old story about the man who built his boat in the basement — ed.) Nail small blocks of wood on the base legs to support each spreader before nailing them in place. Add triangular gussets (part 6) made from 1/4-inch thick marine plywood at the junctions of the spreaders and base legs.

The cross braces can be assembled next, using either the notched wood joint shown in Fig. 4A, for braces nailed to the outside of the legs; or, a block of wood at the point where the spreaders cross, shown in Fig. 4B, when one spreader is nailed to the inside of the legs.

Next, add the rear braces (part 10) to the third base leg, as shown in Fig. 5. An extra set of cross braces (part 8) can be added to the mast about 10 feet up from the ground for added rigidity, if desired. After the base spreaders and cross braces are assembled, balance the mast horizontally across a saw horse or other support. Jiggle one end of the mast up and down and the amount of sway in a strong wind can thus be determined. Additional cross braces can be assembled; however, the bracing shown is sufficient to allow only a little flexibility in strong winds.

Three sway-brace wires should be added to the mast, running from near the top, over the spreaders (part 9) and down to about 9 feet from the bottom end. If the tower will support one end of a wire antenna, install a pulley at the top on the side away from the No. 3 leg. It will be most convenient to insert

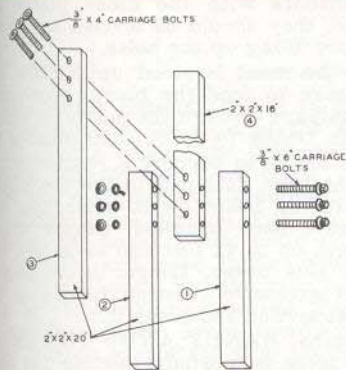

FIG. 2. EXPLODED VIEW of the middle joint between the legs and top section (Parts 1, 2, 3, and 4). Bolt holes are spaced 15 inches apart.

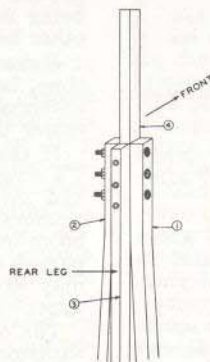

FIG. 3. MIDDLE JOINT assembled. Use washers under all bolt heads and nuts.

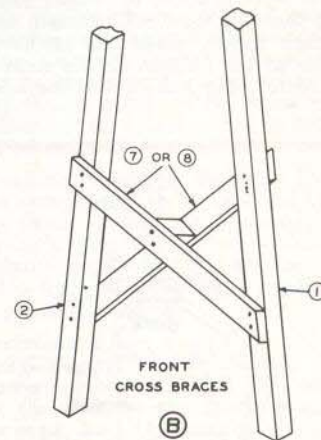
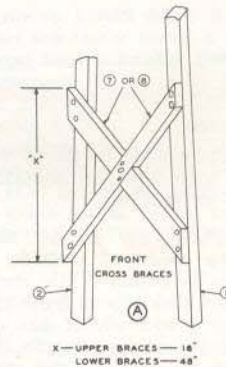

FIG. 4. CROSS BRACE DETAILS, showing (A — top) notched brace; and (B — bottom) simple brace with block between pieces.

TABLE I — BILL OF MATERIALS

WOOD:

- 3 — 2 x 2-inch x 20 feet, fir or white pine (Parts 1, 2, 3)
- 1 — 2 x 2-inch x 16 feet, fir or white pine (Part 4)
- 2 — 1 x 2-inch x 16 feet, fir or white pine (Parts 5, 7, 8, 9, 10)
- 1 — 2 x 4-inch x 14 feet, fir (for base anchors)
- 1 — 6 x 48 x 1/4-inch thick marine plywood (Part 6)

HARDWARE:

- 3 — 3/8 x 6-inch long carriage bolts
- 3 — 3/8 x 4-inch long carriage bolts
- 6 — 3/8-inch washers
- 6 — 3/8-inch nuts to fit carriage bolts
- 18 — 1/4 x 2-inch hex head bolts with nuts and washers
- 2 — strap hinges 1 1/2 inches wide
- 1 — medium size hasp, 1 1/2 inches wide
- 1 — eye bolt
- Nails — 1/4-pound each, No. 4 and No. 8, resin coated
- 1 — quart white house paint
- 75 — feet No. 12 stranded galvanized steel guy wire
- 50 — feet plastic covered nylon core clothesline

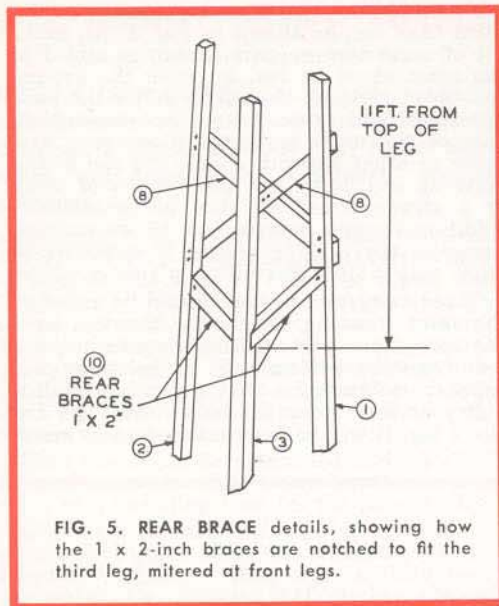

small turnbuckles in these wires and adjust them to hold the top section straight after the mast is vertical.

THE COMPLETED MAST should be given about two coats of outside house paint in your favorite color. While the paint is drying, the ground stakes, cut from the 2 x 4 lumber, should be prepared. If the ground is quite hard, pointed stakes (style B in Fig. 4) can be driven in and should provide adequate anchorage.

For soft ground, or where you want to be sure that the mast will remain anchored even in high winds, make the anchors with cross pieces at the bottom (Style A in Fig. 4). For the latter, dig a hole for the anchor and fill

it up with rocks and dirt, packing it down tightly. The two front legs can be hinged either with shed door hinges, or with bolts run through holes in the legs, as illustrated.

Locate the positions of the anchors for the two front legs by laying the mast on the ground, front side down, with the base at the desired location. Fasten the hinges to the anchor posts with the $\frac{1}{4}$ x 2-inch long bolts. To keep the wood from splitting, place strips of $\frac{1}{8}$ -inch thick metal on the tower legs.

After the legs are fastened, raise the mast up to a vertical position and mark the position of the third anchor. Lower the mast, install the third anchor, raise the mast again and fasten the hasp to the anchor and tower leg with $\frac{1}{4}$ x 2-inch bolts.

Standing off from the mast about 30 or 40 feet, check the mast for vertical alignment in all three directions, and, if necessary, drive one of the stakes a bit further into the ground until the mast is vertical. Of course, if ground anchors with the cross pieces are being used, they should be leveled with each other before filling up the holes.

Before the mast is stood up for the last time, be sure to feed the plastic clothesline antenna halyard through the pulley; it's much easier than trying to do it after mast is up.

If the mast is to support a rotator of the TV antenna type, fasten it to the top section and mount the beam on it after the base anchors have been installed. Beams with a boom length up to 12 feet can be safely supported on this tower. Longer boom lengths may exert excessive twisting torque on the upper mast section and break it.

The original HANDY ANDY TOWER has withstood some very windy weather for more than four years, while supporting a wire antenna. A set of guy wires running from near the top of the upper section at an angle of 30 degrees or more has been found good insurance if a beam with high wind resistance is installed. Guy wires may not be necessary for wire antennas less than 150 feet long.

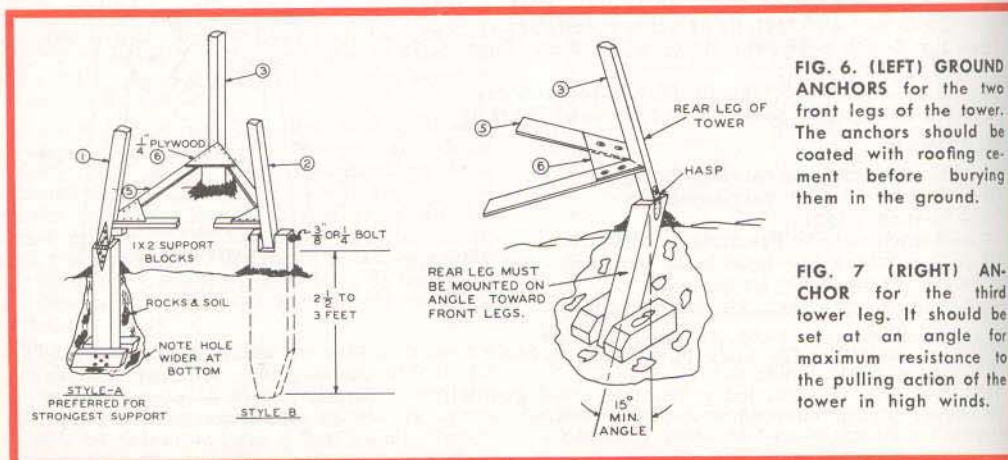

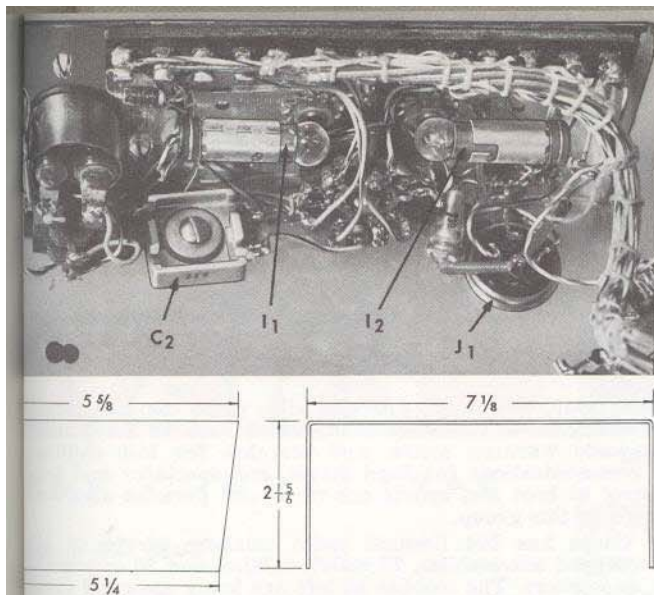

THE CABINET BOTTOM half, with parts and wiring behind the panel exposed. The cable from the center chassis connects to a long row of terminals fastened to the upper edge of the panel. Locations for C_2 and J_1 , on the cabinet bottom, not shown in the cabinet drilling diagram, Fig. 3, can be determined from this view.

FIG. 5. HOODED COVER which can either be installed on the commercially made cabinet, or on a home-made cabinet. A piece of $\frac{1}{8}$ -inch thick sheet aluminum, $13\frac{1}{4} \times 5\frac{5}{8}$ inches over-all, is required.

THE TC-75

(continued from page 5)

The center chassis (bolted to the cabinet by two bolts) holds most of the wiring and parts. Parts should be mounted so they (tubes, transformers and coils) project toward the rear, and the adjusting screws face the front panel, in line with the adjusting holes in the panel. When mounting the chassis, be sure and leave enough room between the center chassis and the rear so the tubes can be removed and inserted. Tuning holes in the front panel are normally covered by plug buttons except the final tuning slug adjustment. For this, a $\frac{1}{4}$ " shaft is drilled and tapped for the slug's 6-32 thread and a $\frac{1}{4}$ " nut is used for a lock nut. This $\frac{1}{4}$ " shaft projects through a hole in the front panel and becomes the only control normally used. C_2 however, is easily accessible on the bottom of the cabinet, just under S_1 .

Wiring is short and direct, making use of tie points where necessary. Filter F_L is mounted on the center chassis, also by tie points. A small bracket holds the relay (K_1) over the antenna loading capacitor (C_2).

The converter tune-up is started by tuning the broadcast receiver to the portion of the 3.8-4.0-megacycle band that is used the most. The RF and mixer slugs are adjusted for maximum signal from a nearby station on about 3.9 megacycles. One of the neat things about a crystal-controlled converter is that the push buttons on the car radio can be set to the ham frequencies you use. No tuning is necessary; just push the button.

The padder capacitor C_2 is peaked on the broadcast band to some weak station about 1000 kilocycles.

THE TRANSMITTER oscillator is tuned by adjusting the slug in L_1 maximum grid current

in the final stage, then backing the slug out (lowering inductance) to about 80 percent of the peak value. This should be about 1 milliamperes or more. Switch the meter to the plate current position and adjust the slug in L_2 for minimum plate current. Adjust the loading control (C_1) for 50 milliamperes plate current at 300 plate volts. Make sure to re-adjust L_2 for resonance after loading the final with C_1 .

A GOOD ANTENNA is the key to good results with this, or even a more powerful mobile rig on the 3.9-megacycle band. Every amateur has his own opinion about the best type of mobile antenna — base-loaded whip, center-loaded whip, helical type whip, etc. — but this little rig has been operated successfully for several months with a base-loaded whip antenna. Normal transmitter working range seems to be about 15 miles on ground wave and up to 250 miles on sky wave propagation (assuming no interference at the receiving end, of course).

A larger cabinet would be desirable for the TC-75 if the components to be used are larger in size than those chosen for this model. An 8 x 6 x 4½-inch interlocking box (LMB No. 146) is available; or, the 8 x 6 x 3½-inch, and 10 x 6 x 3½-inch Minibox type enclosures should be a suitable housing.

Some constructors may even prefer to construct the TC-75 in three connecting units with the power, audio, metering and control circuitry in the middle; the transmitter r.f. unit on one end, and the converter on the other end. This construction technique is particularly adaptable to having separate transmitter r.f. units and converters for 3.9 and 7.2-megacycle operation.

Whatever your choice constructionwise, you'll find the TC-75 ideal for getting started in amateur radio mobile work.



Walter Ermer, Sr., W8AEU

RECIPIENT — 1959

EDISON RADIO AMATEUR AWARD

... chosen by the judges to receive the Eighth Annual Edison Radio Amateur Award in recognition of his outstanding organizational and administrative ability in providing Cleveland, Ohio, with a 300-man voluntary Amateur Radio Emergency Corps.

During 1959, this Corps provided vital radio communications on 23 occasions — including emergencies such as flood, storm and tornado warning alerts, and searches for lost children. Radio communications for fund drives, and spectator and traffic control at boat and sports car races and parades also were furnished by this group.

The Corps has 304 licensed radio amateur operators, 197 radio-equipped automobiles, 77 walkie-talkies, and 26 emergency power generators. The mobiles at left are being assigned storm emergency patrol by Ermer.

The success of this emergency communications corps is directly attributed to Mr. Ermer's organizational ability, plus demonstrating outstanding initiative, diplomacy, tact, imagination and leadership. He has devoted long hours to consulting and planning with officials of the municipal governments, service, safety, civil defense and amateur radio groups in the Cleveland area.

Mr. Ermer received the award trophy and \$500 check at a ceremony in Washington, D.C., on February 25, 1960.



MARCH-APRIL, 1960

VOL. 15 — NO. 2

BUILD-IT-YOURSELF IDEAS

from the 999 radio amateurs of

GENERAL ELECTRIC

published bi-monthly by
RECEIVING TUBE DEPARTMENT

Owensboro, Ky.

Available **FREE** from your
G-E Tube Distributor

E. A. Neal, W4ITC — Editor